

Data sheet

PAH pumps

PAH 2/4/6.3, PAH 10/12.5,
PAH 20/25/32 and
PAH 50/63/70/80/100



Table of Contents	1.	Introduction	2
	2.	Benefits.....	3
	3.	Application examples	3
	4.	Technical data	4
	4.1	PAH 2-12.5	4
	4.2	PAH 20-32	5
	4.3	PAH 50-100	6
	5.	Flow	7
	5.1	PAH 2-6.3 typical flow curves at max pressure	7
	5.2	PAH 10-12.5 typical flow curves at max pressure.....	8
	5.3	PAH 20-32 typical flow curves at max pressure	9
	5.4	PAH 50-100 typical flow curves at max pressure.....	10
	6.	Motor requirements.....	11
	7.	Installation.....	12
	7.1	Filtration	12
	7.2	Noise	12
	7.3	Open-system design	13
	7.4	Closed-system design	14
	8.	Dimensions and connections.....	15
	8.1	PAH 2-6.3	15
	8.2	PAH 10-12.5	16
	8.3	PAH 20-32	17
	8.4	PAH 50-100	18
	9.	Service.....	19

1. Introduction

The data sheet is valid for PAH pumps both non ATEX and ATEX certified. The ATEX certified versions are indicated with Ex in the designation.

All components are designed to provide long service life with a constantly high efficiency and minimum service required.

The Danfoss range of PAH high-pressure pumps is designed to supply water flow under high-pressure for a variety of tap water applications.

In the following all pumps are named PAH.

Danfoss PAH pumps are positive displacement pumps, with axial pistons that move a fixed amount of water in each cycle. Flow is proportional to the number of input shaft revolutions (rpm). Unlike centrifugal pumps, they produce the same flow at a given speed no matter what the discharge pressure.

Below sectional drawing is an example of a PAH pump.

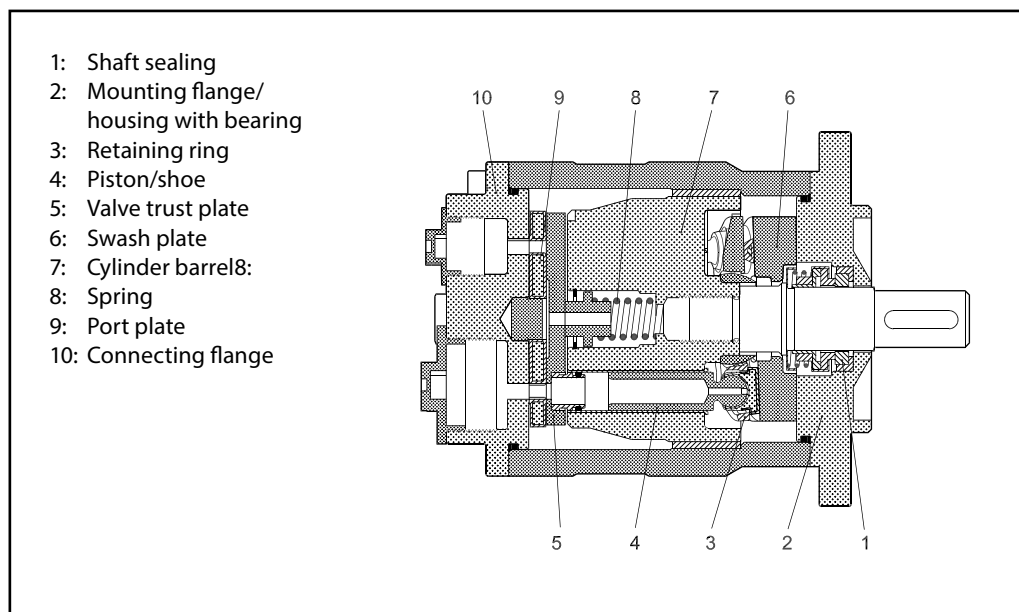

2. Benefits

- **Zero risk of lubricant contamination:**
 - Oil lubricants are replaced with the pumped medium, water, so there is no contamination risk from the pump.
- **Low maintenance costs:**
 - Efficient design and all-stainless steel construction ensure exceptionally long lifetime. When Danfoss specifications are met, service intervals of up to 8,000 hours can be expected. Service is easy, and can be carried out on site due to the simple design and few parts.
- **Low energy costs:**
 - The highly efficient axial piston design provides the lowest energy consumption of any comparable pump on the market.
- **Easy installation:**
 - The lightest and most compact design available.
- Pump can be installed horizontally or vertically.
- No pulsation dampeners necessary due to extremely low-pressure pulsation.
- Powered by electric motors or combustion engines.
- Suitable for both boosted inlet pressure and water supply from a tank.
- No need for cooling circuits due to very high mechanical efficiency.
- **Certified quality:**
 - Certificates: ISO 9001, ISO 14001, ITF 16949
 - ATEX available on request
 - ABS and DNV GL certifications on request

3. Application examples

- Stationary and mobile hydraulic systems
- High-pressure systems
- Fire fighting
- Flushing and cleaning processes
- Humidification systems

4. Technical data

4.1 PAH 2-12.5

Pump size		2	4	6.3	10	12.5
Code number		180B0024	180B0022	180B0023	180B0008	180B0007
Code number ATEX ²⁾		180B6124	180B6122	180B6123	180B6108	180B6107
Housing material		AISI 304	AISI 304	AISI 304	AISI 304	AISI 304
Geometric displacement	cm ³ /rev	2	4	6.3	10	12.5
	in ³ /rev	0.12	0.24	0.38	0.60	0.75
Pressure						
Min. outlet pressure	barg	30	30	30	30	30
	psig	435	435	435	435	435
Max. outlet pressure	barg	140	140	140	160	160
	psig	2030	2030	2030	2320	2320
Inlet pressure, continuous	barg	0-4	0-4	0-4	0-4	0-4
	psig	0-58	0-58	0-58	0-58	0-58
Speed						
Min. speed, continuous	rpm	700	700	700	700	700
Max. speed	rpm	1800	1800	1800	1800	1800
Typical flow - Flow curves available in section 5						
1000 rpm at max. pressure	l/min	1.0	3.2	5.6	8.4	11.0
1500 rpm at max. pressure	l/min	2.0	5.2	8.7	13.4	17.2
1200 rpm at max. pressure	gpm	0.4	1.0	1.8	2.7	3.5
1800 rpm at max. pressure	gpm	0.7	1.7	2.8	4.3	5.5
Typical motor size						
1500 rpm at max. pressure	kW	0.9	1.7	2.6	4.5	5.6
1800 rpm at max. pressure	hp	1.5	2.7	4.2	7.3	9.0
Torque at max. spec.	Nm	5.9	10.9	16.7	29.0	35.8
	lbf-ft	4.4	8.0	12.3	21.4	26.4
Media temperature	°C	2-50	2-50	2-50	2-50	2-50
	°F	36-122	36-122	36-122	36-122	36-122
Ambient temperature	°C	0-50	0-50	0-50	0-50	0-50
	°F	32-122	32-122	32-122	32-122	32-122
Sound pressure level ¹⁾	dB(A)	76	76	76	75	75
Weight	kg	4.4	4.4	4.4	7.7	7.7
	lbs	9.7	9.7	9.7	17.0	17.0

For certified pumps specifications on inlet and outlet pressure is stated on the 3.1 inspection certificate and may vary from generic specifications stated above.

¹⁾ Measurements according to EN ISO 3744: 2010 / dB(A) [L_{PA, 1m}] values are calculated.

Measured at max pressure and rpm for a motor pump unit.

²⁾ Category 2, Zone 1 or Category 3, Zone 2.

4.2 PAH 20-32

Pump size		20	25	32
Code number		180B0079	180B0036	180B0037
Code number ATEX ³⁾		180B6179	180B6136	180B6137
Housing material		AISI 304	AISI 304	AISI 304
Geometric displacement	cm ³ /rev	20	25	32
	in ³ /rev	1.22	1.53	1.95
Pressure				
Min. outlet pressure	barg	30	30	30
	psig	435	435	435
Max. outlet pressure	barg	80	160	160
	psig	1160	2321	2321
Inlet pressure, continuous ¹⁾	barg	0-4	0-4	0-4
	psig	0-58	0-58	0-58
Speed				
Min. speed, continuous	rpm	700	700	700
Max. speed	rpm	1800	1800	1800
Typical flow - Flow curves available in section 5				
1000 rpm at max pressure	l/min	18.8	22.5	29.7
1500 rpm at max pressure	l/min	28.9	35.2	45.9
1200 rpm at max. pressure	gpm	5.9	7.2	9.4
1800 rpm at max. pressure	gpm	9.1	11.1	14.5
Typical motor size				
1500 rpm at max. pressure	kW	4.4	10.8	13.8
1800 rpm at max. pressure	hp	7.1	17.3	22.3
Torque at max. spec.	Nm	28.0	68.5	88.1
	lbf-ft	20.7	50.2	65.0
Media temperature	°C	2-50	2-50	2-50
	°F	36-122	36-122	36-122
Ambient temperature	°C	0-50	0-50	0-50
	°F	32-122	32-122	32-122
Sound pressure level ²⁾	dB(A)	79	79	79
Weight	kg	16	16	16
	lbs	35	35	35

For certified pumps specifications on inlet and outlet pressure is stated on the 3.1 inspection certificate and may vary from generic specifications stated above.

- ¹⁾ Above 1800 rpm inlet pressure 2-6 barg
- ²⁾ Measurements according to EN ISO 3744: 2010 / dB(A) [L_{PA,1m}] values are calculated. Measured at max pressure and rpm for a motor pump unit.
- ³⁾ Category 2, Zone 1 or Category 3, Zone 2.

4.3 PAH 50-100

Pump size		50	63	70	80	100
Code number		180B0047	180B0040	180B0042	180B0041	180B0076
Code number ATEX ²⁾		180B6147	180B6140	180B6142	180B6141	180B6176
Housing material		AISI 304	AISI 304	AISI 304	AISI 304	AISI 304
Geometric displacement	cm ³ /rev	50	63	70	80	100
	in ³ /rev	3.05	3.84	4.27	4.88	6.00
Pressure						
Min. outlet pressure	barg	30	30	30	30	30
	psig	435	435	435	435	435
Max. outlet pressure	barg	80	160	160	160	80
	psig	1160	2321	2321	2321	1160
Inlet pressure, continuous	barg	0-4	0-4	0-4	0-4	0-4
	psig	0-58	0-58	0-58	0-58	0-58
Speed						
Min. speed, continuous	rpm	700	700	700	700	700
Max. speed	rpm	1800	1800/2400 ³⁾	1800/2400 ³⁾	1800/2400 ³⁾	1500
Typical flow - Flow curves available in section 5						
1000 rpm at max. pressure	l/min	47.0	56.2	63.4	73.9	96.7
1500 rpm at max. pressure	l/min	72.1	87.9	98.5	114.1	146.9
1200 rpm at max. pressure	gpm	14.8	17.9	20.1	23.4	30.4
1800 rpm at max. pressure	gpm	22.7	27.8	31.1	35.9	-
2400 rpm at max. pressure	l/min	-	145	162	187	-
Typical motor size						
1500 rpm at max. pressure	kW	10.6	26.8	29.8	34.0	42.6
1800 rpm at max. pressure	hp	17.1	43.1	47.9	54.8	-
Torque at max. spec.	Nm	67.8	170.8	189.7	216.8	135.5
	lbf-ft	50.0	126.0	140.0	160.0	100.0
Media temperature	°C	2-50	2-50	2-50	2-50	2-50
	°F	36-122	36-122	36-122	36-122	36-122
Ambient temperature	°C	0-50	0-50	0-50	0-50	0-50
	°F	32-122	32-122	32-122	32-122	32-122
Sound pressure level ¹⁾	dB(A)	80	80	80	80	81
Weight	kg	31	31	31	31	31
	lbs	68	68	68	68	68

For certified pumps specifications on inlet and outlet pressure is stated on the 3.1 inspection certificate and may vary from generic specifications stated above.

¹⁾ Measurements according to EN ISO 3744: 2010 / dB(A) [L_{PA, 1m}] values are calculated. Measured at max pressure and rpm for a motor pump unit.

²⁾ Category 2, Zone 1 or Category 3, Zone 2.

³⁾ If PAH 63/70/80 run 1800 - 2400 rpm the following conditions apply:
Inlet pressure 2 -4 barg, outlet pressure max. 140 barg for a maximum of 500 hours in between service inspection

5. Flow

The flow (Q_{eff}) at various pressure (p_{max}) can be calculated with the following equation:

$$Q_{eff} = Q_{(th)} - [(Q_{(th)} - Q(p_{max})) \times (p / p_{max})]$$

The theoretical flow can be calculated with the following equation:

$$Q_{(th)} = \frac{V \times n}{1000}$$

At zero pressure the true flow equals the theoretical flow $Q_{(th)}$.

- | | |
|----------------|---|
| $Q_{(th)}$: | Theoretical flow (l/min / gpm) |
| $Q(p_{max})$: | Flows at max. pressure (l/min and gpm), see 4.1-4.4 |
| p_{max} : | Max pressure (barg / psig) |
| p : | Pressure (barg / psig) |
| V : | Displacement ($cm^3 / rev.$) |
| n : | Motor speed (rpm) |

5.1 PAH 2-6.3 typical flow curves at max pressure

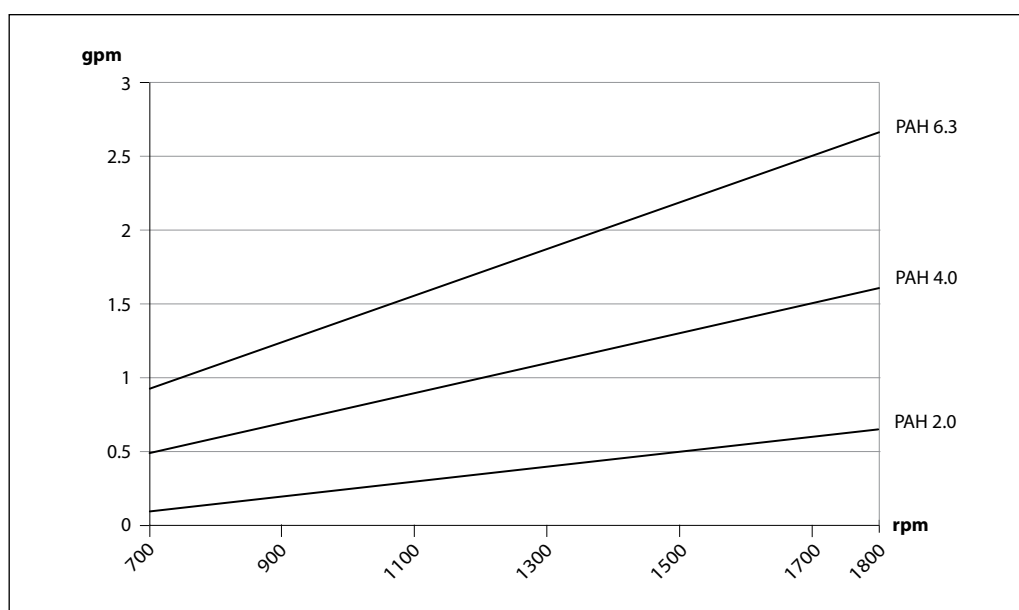
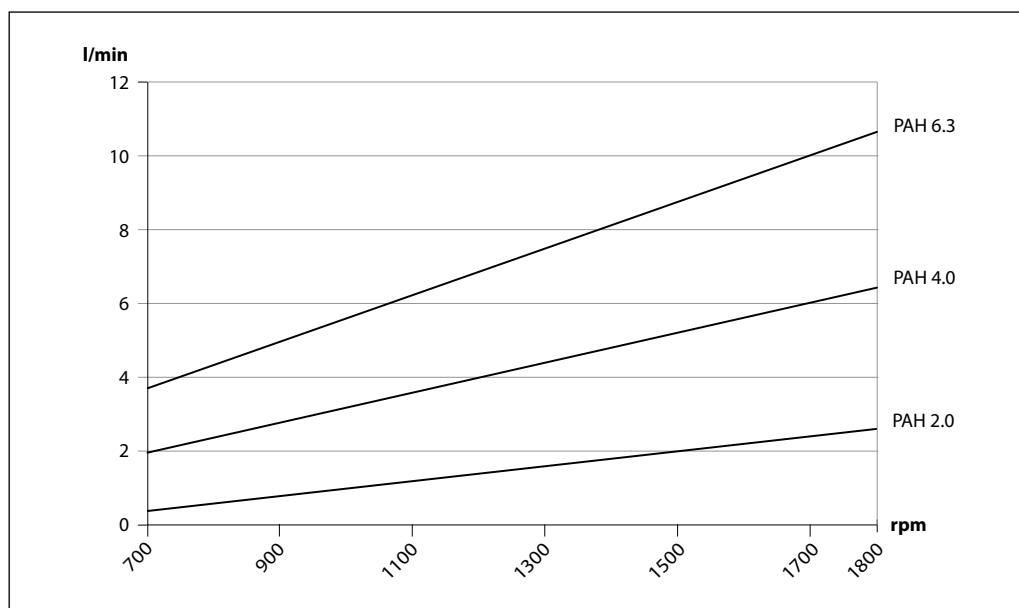

5.2 PAH 10-12.5 typical flow curves at max pressure

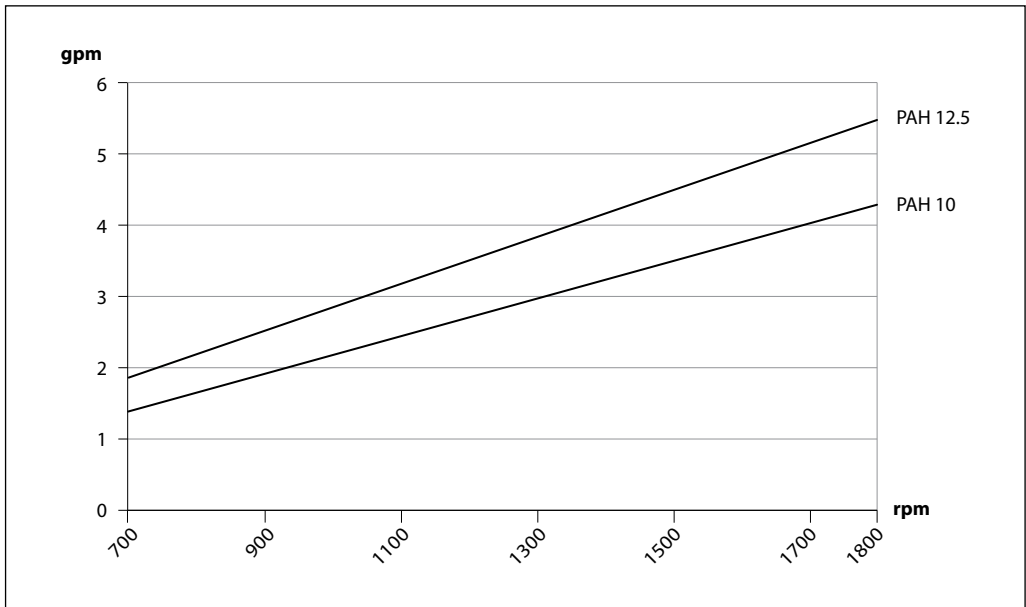
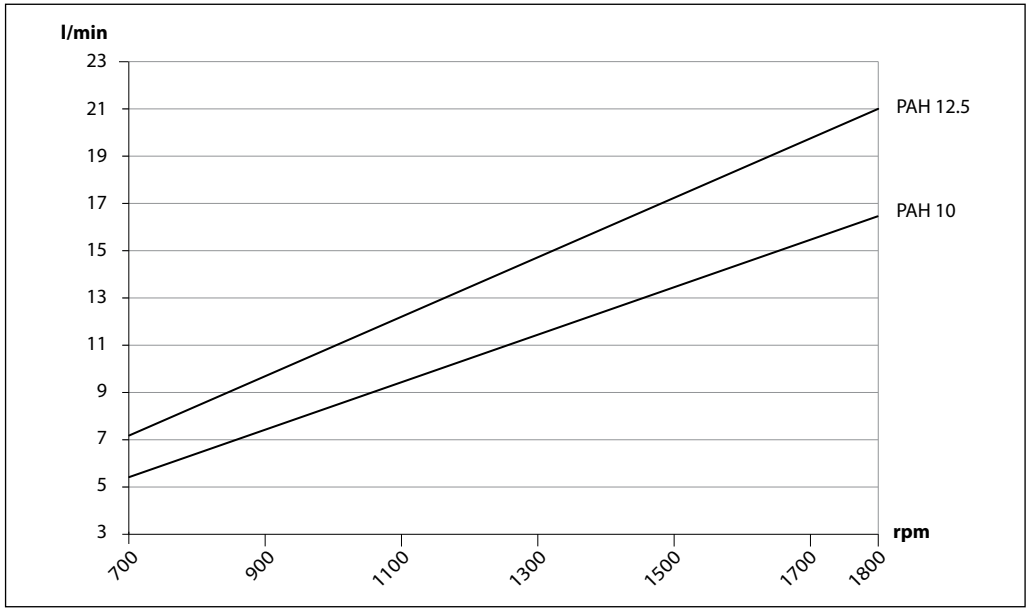

5.3 PAH 20-32 typical flow curves at max pressure

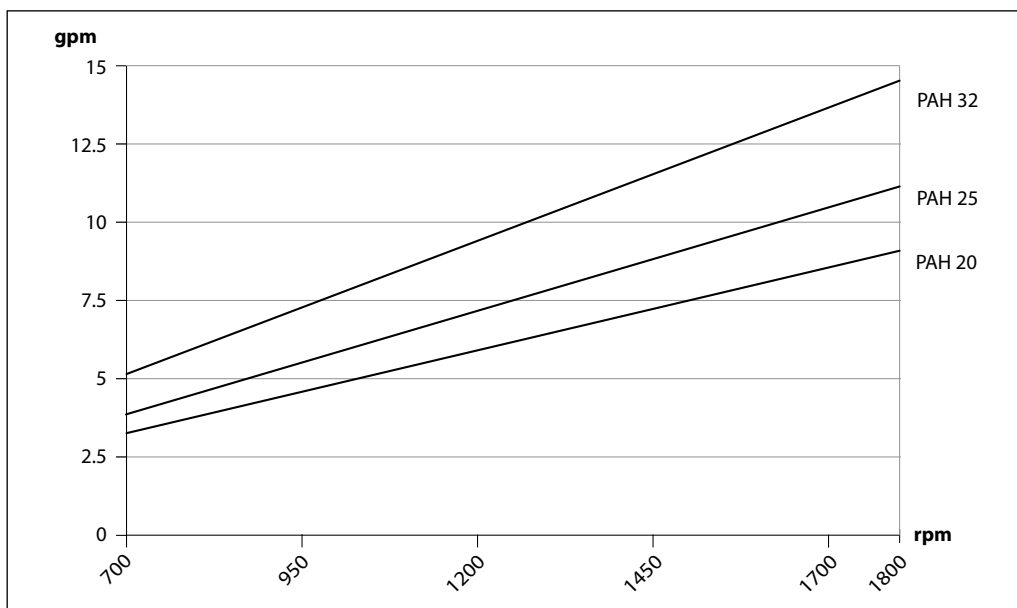
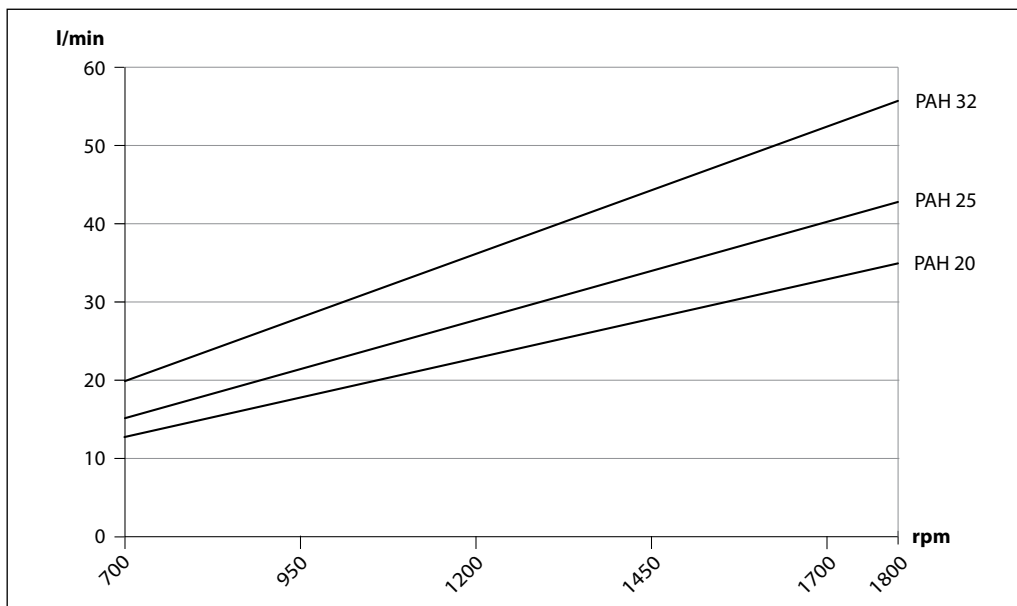

5.4 PAH 50-100 typical flow curves at max pressure

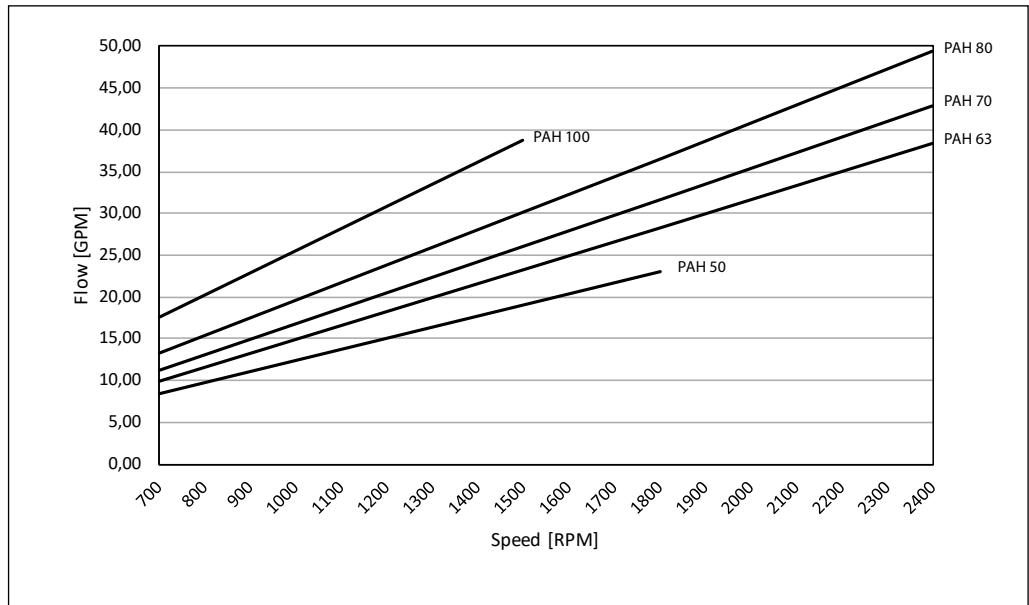
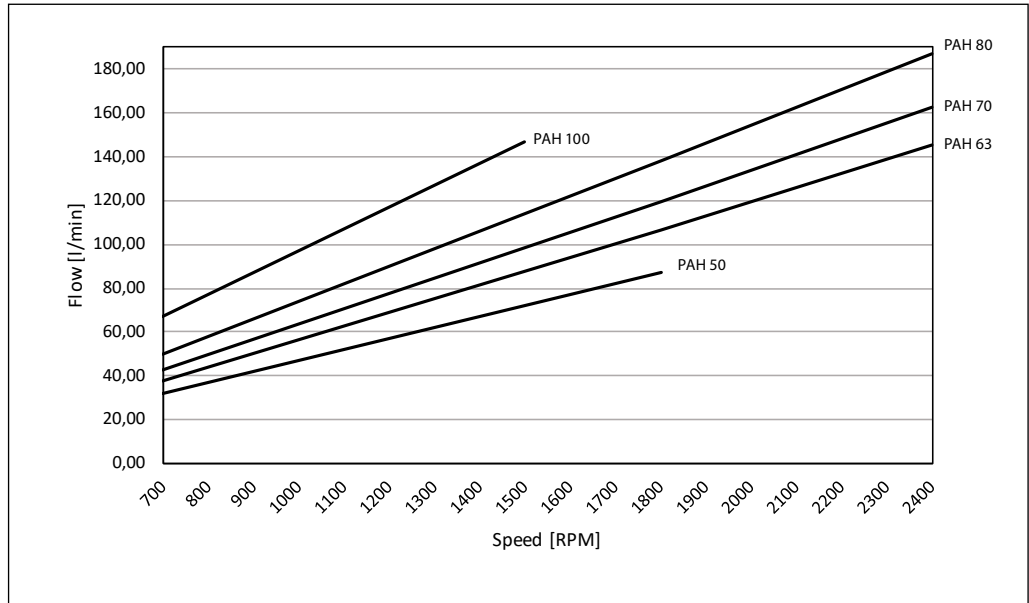

If PAH 63/70/80 run 1800 - 2400 rpm the following conditions apply:
 Inlet pressure 2 -4 barg, outlet pressure max. 140 barg
 for a maximum of 500 hours in between service inspection.

6. Motor requirements

The required motor power can be calculated by using the following equation:

$$P = \frac{n \times V \times p}{600.000 \times \eta}$$

P: Power (kW)
 M: Torque (Nm)
 η: Mechanical efficiency
 p: Pressure (barg)
 n: Motor speed (rpm)
 V: Displacement (cm³/rev.)

From the flow curves in item 5, you can determine the rpm of the pump at the desired flow.

The required torque is calculated as follows:

$$M = \frac{V \times p}{62.8 \times \eta}$$

To determine the correct motor size, both the power and torque requirement must be verified.

The mechanical efficiency of the pump, at max pressure, is as follows:

PAH 2, 4, 6.3	0.82
PAH 10, 12.5	0.9
PAH 20, 25, 32, 50, 63, 70, 80, 100	0.95

7. Installation

See the figure below for instructions on how to mount the pump and connect it to an electric motor or combustion engine.

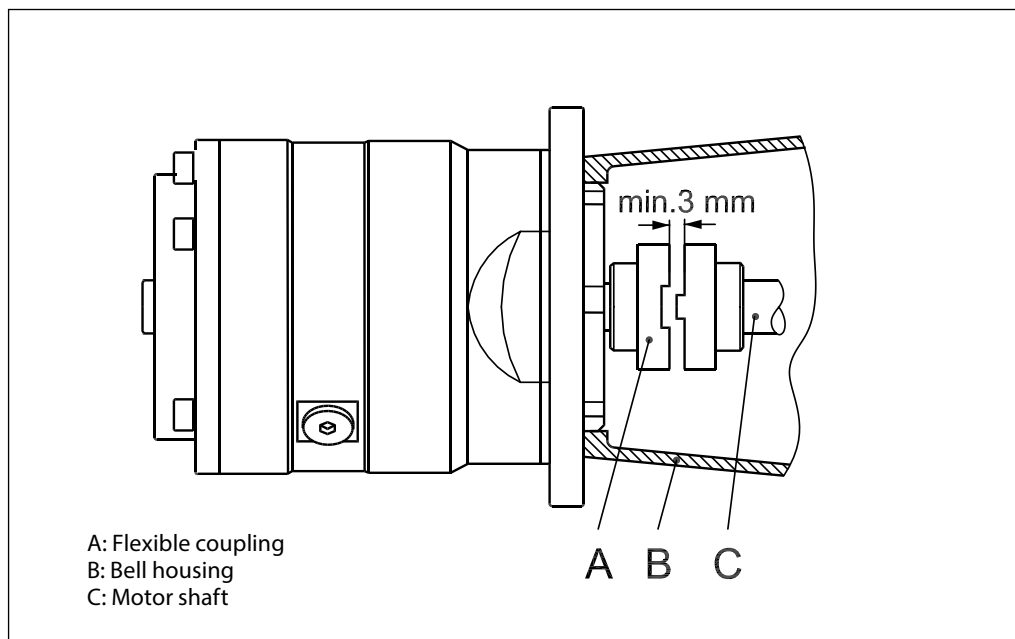

If alternative mounting is required, please contact your Danfoss sales representative for further information.

Note: Do not add any axial or radial loads to the pump shaft.

For more information on the importance of proper filtration, including explanation of filtration principles, definitions, and guidance on how to select the right filter for your pump, please consult our **Filtration** information and specifications (Danfoss document number 521B1009).

7.1 Filtration

Proper filtration is crucial for the performance, maintenance and warranty of your pump.

Protect your pump, and the application in which it is installed, by always ensuring that filtration specifications are met, and by always changing filter cartridges according to schedule.

Since water has very low viscosity, Danfoss PAH pumps have been designed with very narrow clearances in order to control internal leakage rates and improve component performance. **To minimize wear in the pump, it is therefore essential to filter inlet water properly.**

The main filter must have a filtration efficiency of 99.98% at 10 µm. We strongly recommend that you always use precision depth filter cartridges rated 10 µm abs. $\beta_{10} \geq 5,000$.

Please note that **we do not recommend bag filters or string-wound filter cartridges**, which typically have only 50% filtration efficiency. This means that out of 100,000 particles that enter such filters, 50,000 particles pass right through them; compare this to precision depth filters that are 99.98% efficient, and only allow 20 of the same 100,000 particles to pass through.

7.2 Noise

Since the pump unit is mounted on a frame, the overall noise level can only be determined for a complete system. To minimize vibrations and noise throughout the system, it is therefore very important to mount the pump unit correctly on a frame with dampers and to use flexible hoses rather than metal pipes where possible.

The noise level is influenced by:

- **Pump speed:**
High rpm makes more fluid/structure-borne pulsations/vibrations than low rpm.
- **Discharge pressure:**
High pressures make more noise than low pressures.
- **Pump mounting:**
Rigid mounting makes more noise than flexible mounting because of the structure-borne vibrations. Be sure to use dampers when mounting.
- **Connections to pump:**
Pipes connected directly to the pump make more noise than flexible hoses because of structure-borne vibrations.
- **Variable frequency drives (VFDs):**
Motors regulated by VFDs can produce more noise if the VFD does not have the right settings.

7.3 Open-system design

- A Inlet line:**
Dimension the inlet line to obtain minimum pressure loss (large flow, minimum pipe length, minimum number of bends/connections, fittings with small pressure losses and restrictions).
- B Inlet filter:**
Install the inlet filter (1) in front of the PAH pump (2). Please consult the Danfoss filter data sheet for guidance on how to select the right filter.
- C Monitoring pressure switch:**
Install the monitoring pressure switch (3) between the filter and the pump inlet. Set the minimum inlet pressure according to specifications described in item 4, technical data. The monitoring pressure switch stops the pump if inlet pressure is lower than the set minimum pressure.
- D Monitoring temperature switch:**
Install the monitoring temperature switch (4) between the filter and the pump, on either side of the monitoring pressure switch. Set the temperature value according to technical data, item 4. The monitoring temperature switch stops the pump if inlet temperature is higher than the set value.

- E Hoses:**
Always use flexible hoses (5) to minimize vibrations and noise.
- F Inlet pressure:**
In order to eliminate the risk of cavitation and other pump damage, pump inlet pressure must be maintained according to specifications described in item 4, technical data.
- G Non-return valve (6):**
Should be installed after the outlet to prevent pump backspin, which may ruin the pump.
- H Pressure relief valve:**
As the Danfoss PAH pump begins to create pressure and flow immediately after start-up regardless of any counter pressure, a pressure relief valve (7) should be installed to prevent system damage.

Note: If a non-return valve is mounted in the inlet line, a low-pressure relief valve is also recommended between the non-return valve (8) and the pump to protect against high-pressure peaks.

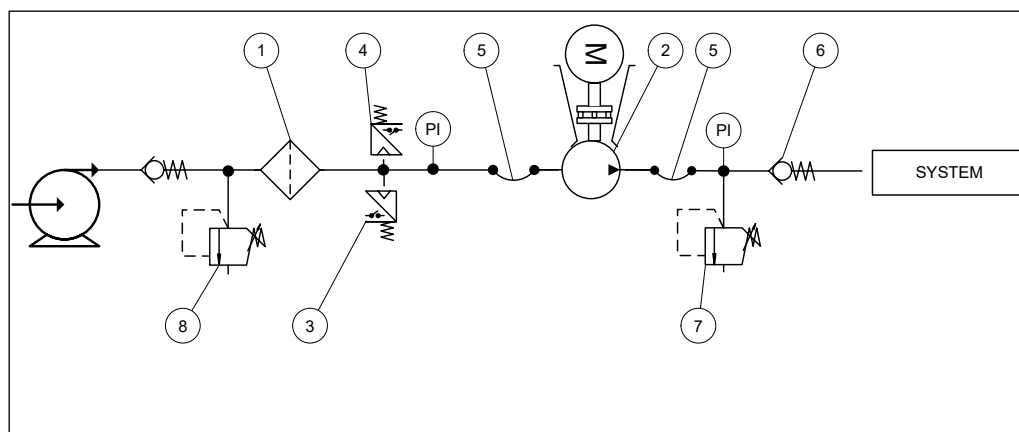

7.4 Closed-system design

- A Inlet line:**
Dimension the inlet line to obtain minimum pressure loss (large flow, minimum pipe length, minimum number of bends/connections, fittings with small pressure losses and restrictions).
- B Inlet filter:**
Install the filter (1) in front of the tank (2). Please consult the Danfoss filter data sheet for guidance on how to select the right filter.
- C Monitoring pressure switch:**
Install the monitoring pressure switch (3) in front of the filter (1). Set the maximum inlet pressure to 2 barg (29.0 psig). The monitoring pressure switch will stop the pump (5) if inlet pressure is higher than 2 barg (29.0 psig), indicating that the filter element must be changed.
- D Monitoring temperature switch:**
Install the monitoring temperature switch (4) in the tank. Set the temperature value according to technical data, item 4. The monitoring temperature stops the pump if inlet temperature is higher than the set value.
- E Hoses:**
Always use flexible hoses (6) to minimize vibrations and noise.
- F Inlet pressure:**
In order to eliminate the risk of cavitation and other pump damage, pump inlet pressure must be maintained according to specifications described in item 4, technical data.
- G Non-return valve (7):**
Should be installed after the outlet to prevent pump backspin, which may ruin the pump.
- H Pressure relief valve:**
As the Danfoss PAH pump begins to create pressure and flow immediately after start-up regardless of any counter pressure, a pressure relief valve (8) should be installed to prevent system damage.
- I System water filling:**
To ensure proper filtration of new water (10) supplied to the system, always use the filling valve (9).
- J Minimum level switch:**
Install the minimum level switch (11) above the outlet of the reservoir. The level switch must stop the pump if the water in the reservoir is below the switch, which indicates that the reservoir is empty.

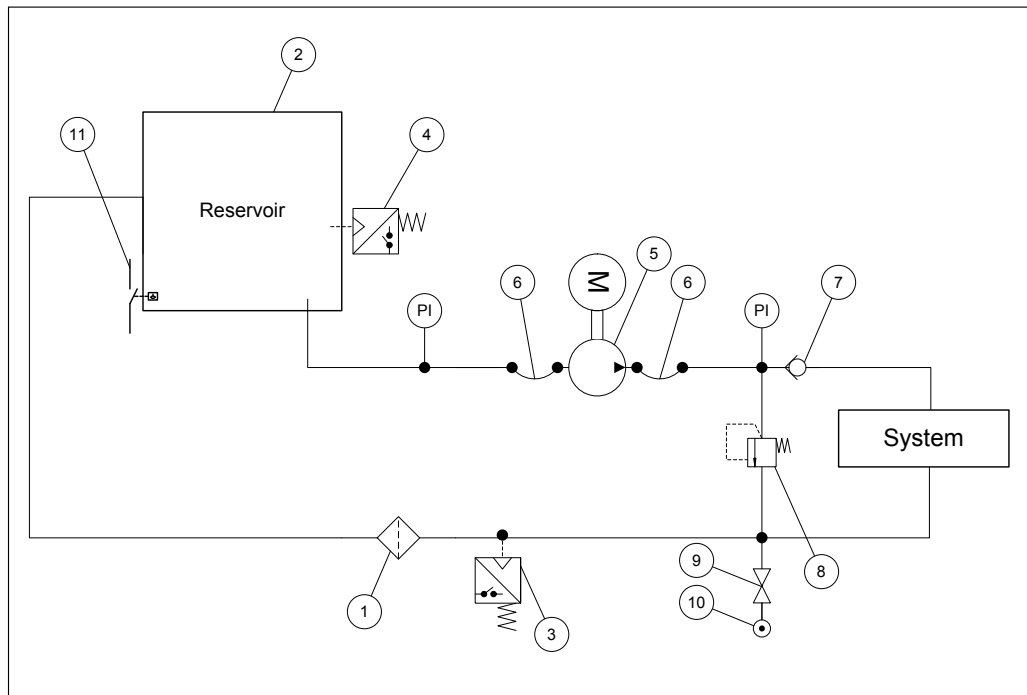

8. Dimensions and connections

8.1 PAH 2-6.3

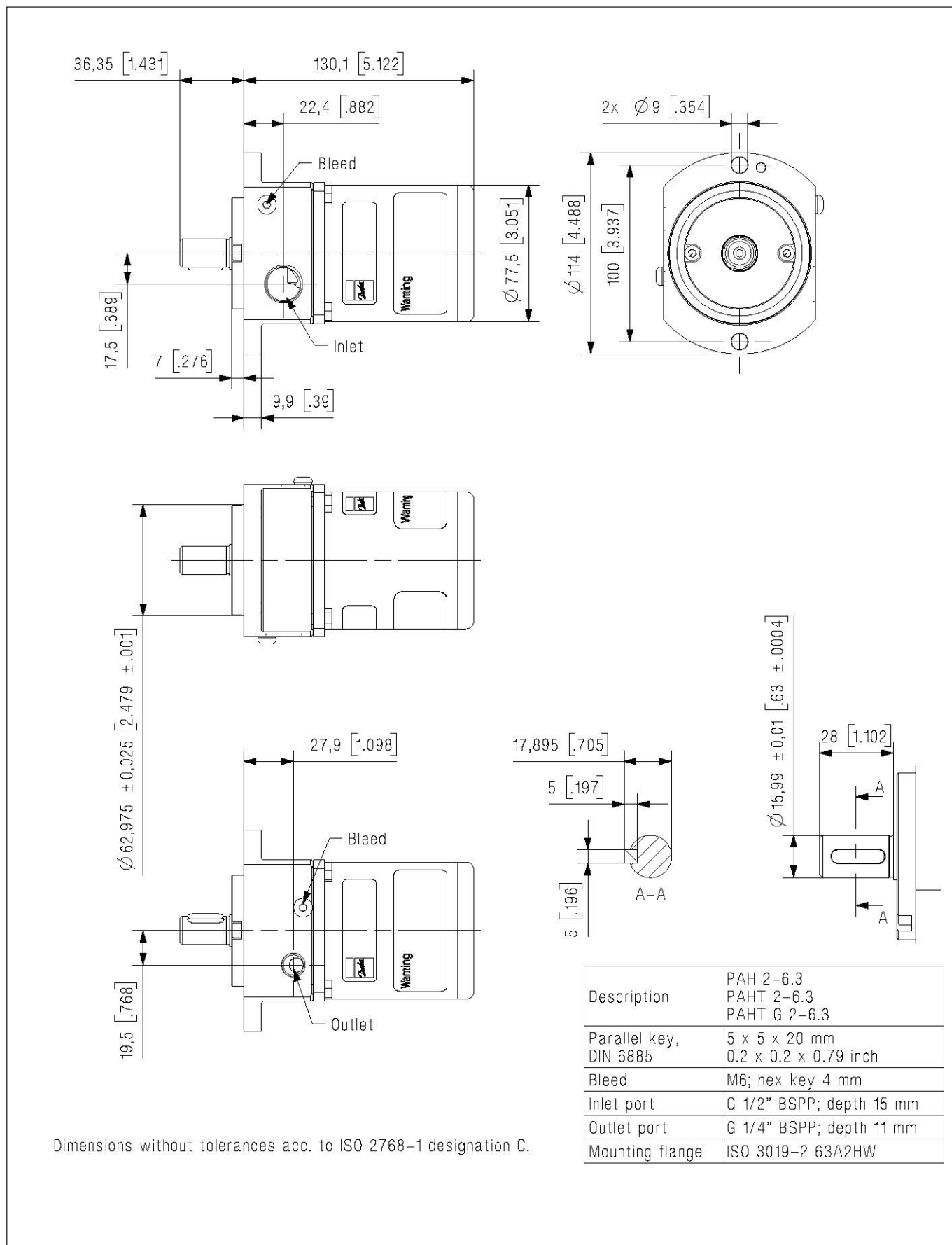

8.2 PAH 10-12.5

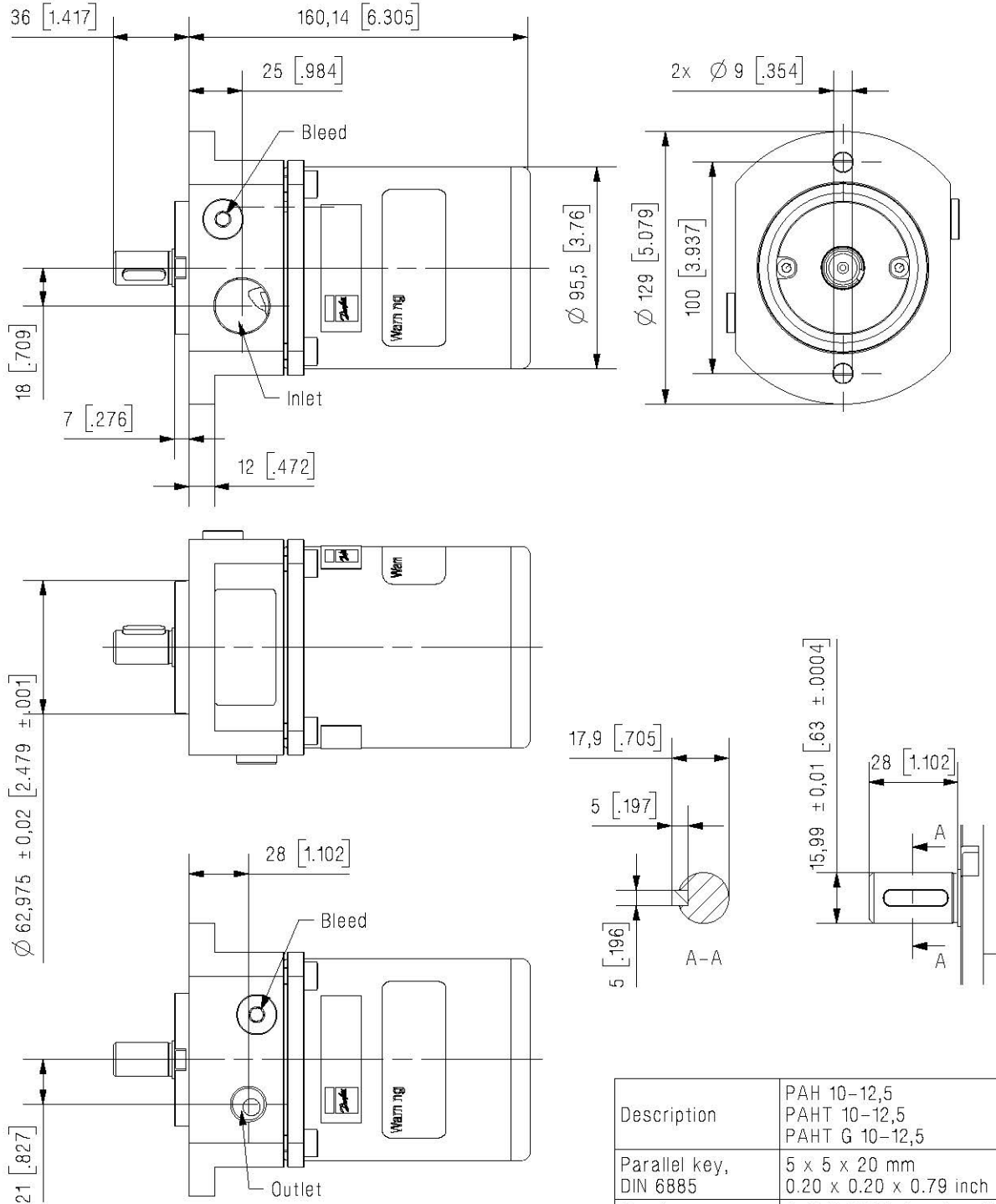

Dimensions without tolerances acc. to ISO 2768-1 designation C.

Description	PAH 10-12,5 PAHT 10-12,5 PAHT G 10-12,5
Parallel key, DIN 6885	5 x 5 x 20 mm 0.20 x 0.20 x 0.79 inch
Bleed	G 1/4" BSPP; hex key 6 mm
Inlet port	G 3/4" BSPP; depth 17 mm
Outlet port	G 3/8" BSPP; depth 15 mm
Mounting flange	ISO 3019-2 63A2HW

8.3 PAH 20-25

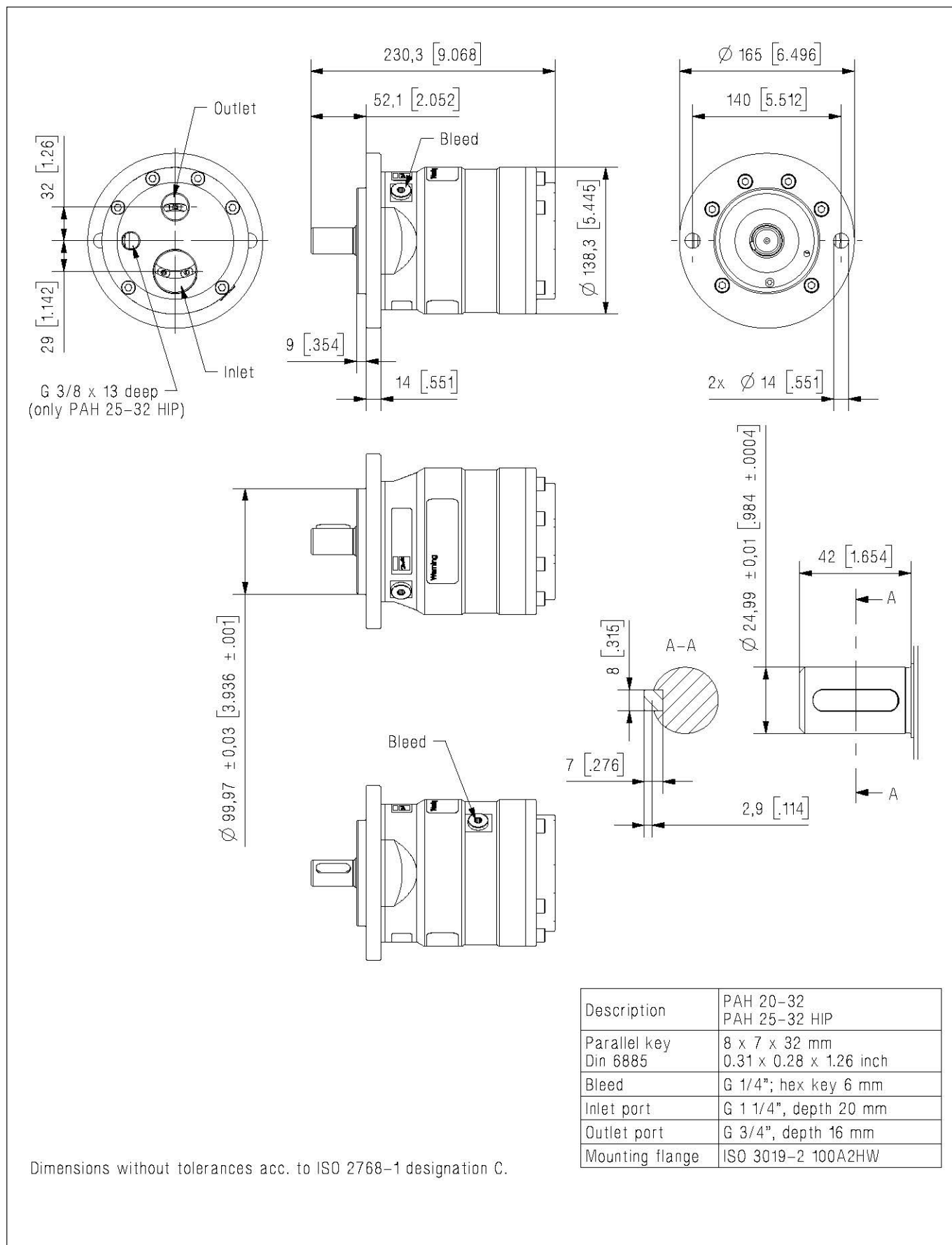

8.4 PAH 50-100

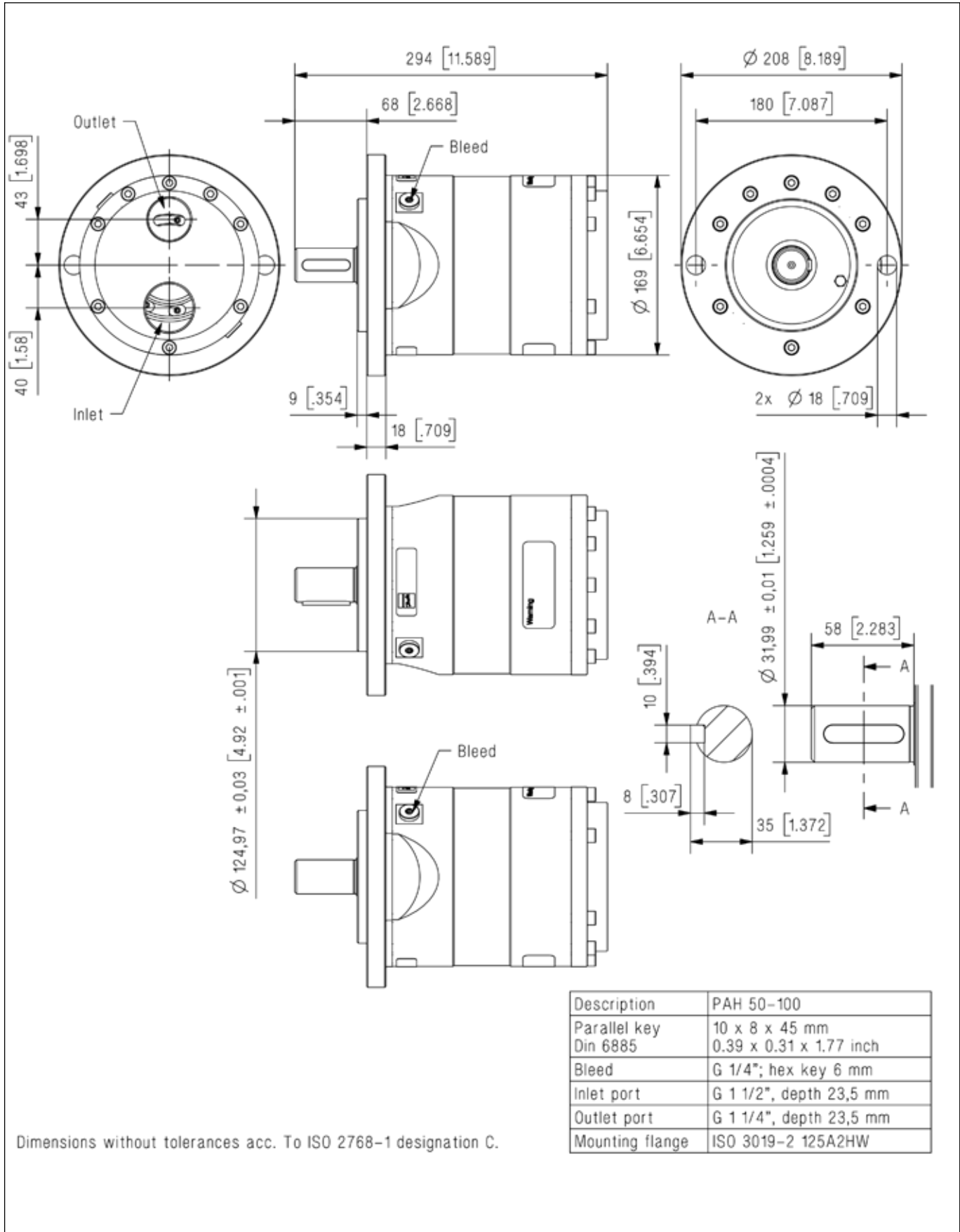

Description	PAH 50-100
Parallel key	10 x 8 x 45 mm 0.39 x 0.31 x 1.77 inch
Bleed	G 1/4"; hex key 6 mm
Inlet port	G 1 1/2", depth 23,5 mm
Outlet port	G 1 1/4", depth 23,5 mm
Mounting flange	ISO 3019-2 125A2HW

Dimensions without tolerances acc. To ISO 2768-1 designation C.

9. Service

Danfoss PAH pumps are designed for long periods of service-free operation to ensure low maintenance and life cycle costs. Provided that the pump is installed and operated according to Danfoss specifications, Danfoss PAH pumps typically run 8,000 hours between service. However, the service schedule for your Danfoss PAH pump may vary according to the application and other factors.

The life of a pump may be greatly shortened if Danfoss recommendations concerning system design and operation are not followed.

In our experience, poor filtration is the number one cause of pump damage.

Other factors that affect pump performance and lifetime include:

- running the pump at speeds outside specifications
- supplying the pump with water at temperatures higher than recommended
- running the pump at inlet pressures outside specifications
- running the pump at outlet pressures outside the specifications.

We recommend that you inspect your pump after 8,000 hours of operation even if it is running without any noticeable problems. Replace any worn parts if necessary, including pistons and shaft seals, to keep your pump running efficiently and to prevent breakdown. If worn parts are not replaced, then our guidelines recommend more frequent inspection.

Danfoss A/S

Nordborgvej 81
High Pressure Pumps
DK-6430 Nordborg
Denmark

Danfoss can accept no responsibility for possible errors in catalogues, brochures and other printed material. Danfoss reserves the right to alter its products without notice.
This also applies to products already on order provided that such alterations can be made without subsequential changes being necessary in specifications already agreed.
All trademarks in this material are property of the respective companies. Danfoss and the Danfoss logotype are trademarks of Danfoss A/S. All rights reserved.
